

9

ИНСТРУМЕНТЫ И ЭКСПЛУАТАЦИОННЫЕ МАТЕРИАЛЫ









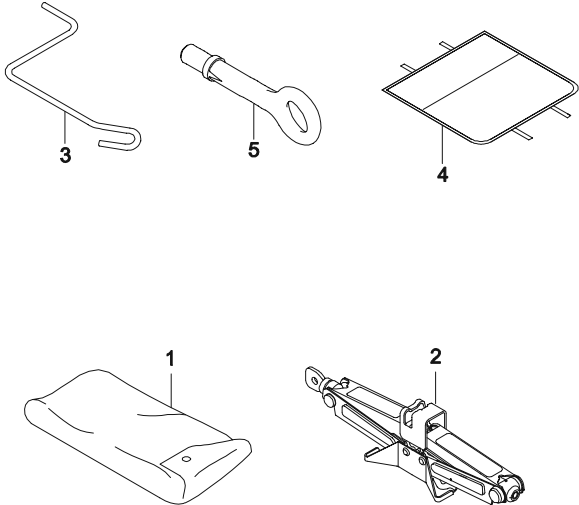

9110 ИНСТРУМЕНТЫ

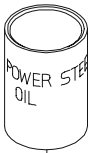
9120 МАСЛО, СМАЗОЧНЫЙ МАТЕРИАЛ И КРАСКА

9210 СПОЙЛЕР

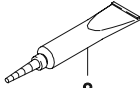
9610 ДУГИ КРЫШИ

9110 ИНСТРУМЕНТЫ TOOL	В З Т	№ ПОЗИЦИИ	КОД / К	НАИМЕНОВАНИЕ				К О Д / Д			
		НОМЕР ДЕТАЛИ	К П П	МОДЕЛЬ	КОМПЛЕКТАЦИЯ	Л / П	К О Л		ПРИМЕНЕНИЕ		ПРИМЕЧАНИЕ
									С	ПО	
	[01] 94535625	-	09800 S S S	(P) КОМПЛЕКТ ИНСТРУМЕНТОВ		1			(A) TOOL A		
	[02] 96315518	-	44D001 S S S	(P) ДОМКРАТ		1			(A) JACK A		
	[03] 96314950	-	44D002 S S S	(P) РУЧКА ДОМКРАТА		1			(A) HANDLE JACK		
	[04] 94535633	-	09811 S S S	(P) СУМКА ДОМКРАТА		1			(A) BAG JACK		
	[05] 96518605	-	S S S	(P) ПЕТЛЯ БУКСИРОВОЧНАЯ		1			(A) BOLT-TOWING EYE		

9120	МАСЛО, СМАЗОЧНЫЙ МАТЕРИАЛ И КРАСКА OIL & PAINT	В З Т	№ ПОЗИЦИИ		КОД / К		НАИМЕНОВАНИЕ				К О Д / Д			
			НОМЕР ДЕТАЛИ	К П П	МОДЕЛЬ			КОМПЛЕКТАЦИЯ	Л / П	К О Л		ПРИМЕНЕНИЕ		ПРИМЕЧАНИЕ
					S	S E	S D					С	ПО	
 1  2  4  5  6  7  8  9  10  11  12	93740036	-	S	S	-	&ORANGE	1			57U(0.5 л)				
	93740037	-	S	S	-	&STAIN BEIGE	1			63U(0.5 л)				
	93740038	-	S	S	-	&POLY SILVER-METALLIC	1			92U(0.5 л)				
	[11] U/T-10L-4L-1	-	S	S	S	(P) КРАСКА &CASABLANKA WHITE	1		(A) PAINT	10L(4 л)				
	93740041	-	S	S	S	&COBALT BLUE	1			25U(4 л)				
	93740042	-	S	S	S	&GOLDEN YELLOW	1			51U(4 л)				
	B/C-76L-4L	-	S	S	S	&CRIMSON RED	1			76L(4 л)				
	93740046	-	S	S	-	&GREEN-GREY,METAL 139	1			39U(4 л)				
	93740047	-	S	S	-	&ORANGE	1			57U(4 л)				
	93740048	-	S	S	-	&STAIN BEIGE	1			63U(4 л)				
	93740049	-	S	S	-	&POLY SILVER-METALLIC	1			92U(4 л)				
	[12] U/T-CLR-4L-1	-	S	S	S	(P) РАСТВОРИТЕЛЬ	1		(A) CLEAR-PAINT					
93740051	-	S	S	S		1								

9210	СПОЙЛЕР SPOILER	В З Т	№ ПОЗИЦИИ		КОД / К			НАИМЕНОВАНИЕ				К О Д / Д			
			НОМЕР ДЕТАЛИ		К П П	МОДЕЛЬ			КОМПЛЕКТАЦИЯ	Л / П	К О Л		ПРИМЕНЕНИЕ		ПРИМЕЧАНИЕ
						S	S E	S D					С	ПО	
			[01] 96507763	- -	0 0			(P) СПОЙЛЕР			1	20040901	(A) SPOILER A		
			[02] 94515117	- -	0 0			(P) ГАЙКА			3	20040901	(A) NUT		
			[03] 96283272	- -	0 0			(P) ПРОКЛАДКА			3	20040901	(A) SEAL		

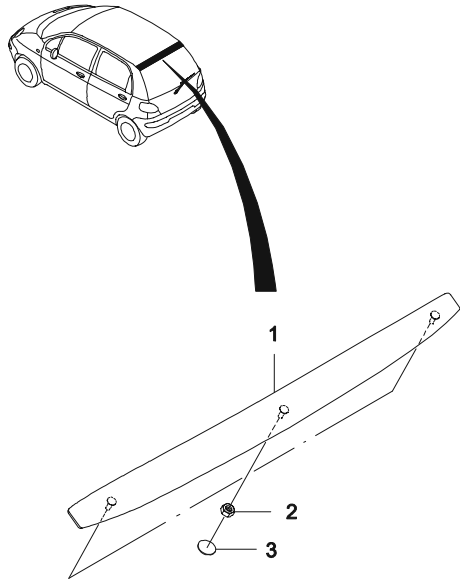

9610	ДУГИ КРЫШИ ROOF RACK	В З Т	№ ПОЗИЦИИ		КОД / К		НАИМЕНОВАНИЕ				К О Д / Д	
			НОМЕР ДЕТАЛИ	К П П	МОДЕЛЬ	КОМПЛЕКТАЦИЯ	Л / П	К О Л	ПРИМЕНЕНИЕ			ПРИМЕЧАНИЕ
									С	ПО		
			[01] 96323331	-	64G025	(P) ДУГА КРЫШИ &WSP/EY2	ЛВ 1			(A) RACK A-ROOF		
			[02] 96323332	-	64G025	(P) ДУГА КРЫШИ &WSP/EY2	ПР 1			(A) RACK A-ROOF		
			[03] 96323337	-	64G023	(P) ПРОКЛАДКА ДУГИ ПЕРЕДНЯЯ &WSP/EY2	ЛВ 1			(A) PAD-ROOF RACK,FRT		
			[04] 96323338	-	64G023	(P) ПРОКЛАДКА ДУГИ ПЕРЕДНЯЯ &WSP/EY2	ПР 1			(A) PAD-ROOF RACK,FRT		
			[05] 96323339	-	64G024	(P) ПРОКЛАДКА ДУГИ ЗАДНЯЯ &WSP/EY2	ЛВ 1			(A) PAD-ROOF RACK,RR		
			[06] 96323340	-	64G024	(P) ПРОКЛАДКА ДУГИ ЗАДНЯЯ &WSP/EY2	ПР 1			(A) PAD-ROOF RACK,RR		
			[07] 96323347	-	0	(P) КРЫШКА ДУГИ &EY2	ЛВ 1			(A) CAP-FRT		
			[08] 96323348	-	0	(P) КРЫШКА ДУГИ &EY2	ПР 1			(A) CAP-FRT		
			[09] 96323349	-	0	(P) КРЫШКА ДУГИ &EY2	ЛВ 1			(A) CAP-RR		
			[10] 96323350	-	0	(P) КРЫШКА ДУГИ &EY2	ПР 1			(A) CAP-RR		
			[11] 08316-25060	-	08316	(P) ГАЙКА &EY2	8			(A) NUT 2004031		
			Y 94515117	-	0	&EY2	8			20040316		
			[12] 96507945	-	0	(P) КРОНШТЕЙН &EY2	4			(A) BRACKET-ROOF RACK		
			[13] 96323431	-	64G013	(P) МОЛДИНГ КРЫШИ, ПЕРЕДНИЙ &EY2	ЛВ 1			(A) MOLDING A-ROOF FRT		
			[14] 96323432	-	64G013	(P) МОЛДИНГ КРЫШИ, ПЕРЕДНИЙ &EY2	ПР 1			(A) MOLDING A-ROOF FRT		
			[15] 96323433	-	64G013	(P) МОЛДИНГ КРЫШИ, ЦЕНТРАЛЬНЫЙ &EY2	ЛВ 1			(A) MOLDING A-ROOF CTR		
			[16] 96323434	-	64G013	(P) МОЛДИНГ КРЫШИ, ЦЕНТРАЛЬНЫЙ &EY2	ПР 1			(A) MOLDING A-ROOF CTR		
			[17] 96323435	-	64G013	(P) МОЛДИНГ КРЫШИ, ЗАДНИЙ &EY2	ЛВ 1			(A) MOLDING A-ROOF RR		

